



EARTHBOUND CORPORATION SlackJack® and MiniJack® Shrinkage Compensation Devices

CSI Section: 06 05 23 - Wood, Plastic and Composite
Fastenings

1.0 RECOGNITION

SlackJack and MiniJack, manufactured by Earthbound Corporation, were evaluated for use as compression-controlled shrinkage compensation devices in wood-framed construction.

The structural properties of the devices were evaluated for compliance with the following codes and regulations:

- 2015, 2012, 2009 and 2006 International Building Code® (IBC)
- 2015, 2012, 2009 and 2006 International Residential Code® (IRC)
- 2013 California Building Code (CBC) – See attached Supplement
- 2013 California Residential Code (CRC) – See attached Supplement
- 2014 Florida Building Code, Building (FBC, Building)- See attached Supplement
- 2014 Florida Building Code, Residential (FBC, Residential)-See attached Supplement
- ICC Acceptance Criteria for Shrinkage Compensating Devices (AC316), dated June 2013 (Editorially Revised March 2015)

2.0 LIMITATIONS

Use of the SlackJack and MiniJack Shrinkage Compensation Devices recognized in this report are subject to the following limitations:

2.1 The SlackJack and MiniJack devices shall be limited to installations in dry, interior locations.

2.2 Use of the SlackJack and MiniJack devices in direct contact with fire-retardant or preservative-treated wood is beyond the scope of recognition of this report.

2.3 Where required, designs using these products shall be submitted to the building code official for review.

2.4 No increase in the allowable capacities shown in Table 3 shall be permitted.

2.5 The dead load is limited to the self-weight of the SlackJack and MiniJack devices. Additional dead load on the devices is beyond the scope of this report.

2.6 The maximum offset tolerance is 1.33 degrees from vertical.

2.7 “When the devices are used in continuous rod systems that resist light-frame shear wall overturning forces, calculations shall be submitted to the code official confirming that the total vertical displacement, which would include steel rod elongation and the shrinkage compensating device deflection, is less than or equal to 0.20 inch (5 mm) for each story, or between restraints, whichever is more restrictive, using allowable stress design (ASD). Shear wall drift limit calculations shall consider the 0.20 inch (5 mm) vertical displacement limit. This 0.20-inch (5 mm) vertical displacement limit may be exceeded when it can be demonstrated that the shear wall story drift limit and the deformation compatibility requirements of IBC Section 1604.4 are met when considering all sources of vertical displacement.” (AC316)

2.8 Buildings constructed to the IRC shall have engineered designs performed on the elements of construction using this device as required in Section R301.1.3.

3.0 PRODUCT USE INSTRUCTIONS

3.1 The Earthbound installation instructions, this evaluation report, and the applicable provisions of the building code shall be followed when installing this product. Where conflicts occur between these documents, the more restrictive provisions shall govern. The published installation instructions shall be available at the jobsite during construction for use by installers and for quality assurance.

3.2 Where required by the authority having jurisdiction, calculations based on applied loads to the device shall be provided by a registered design professional to show the basis for its selection. The calculations must show the projected shrinkage, deflection, and settlement the device will compensate for, and the method of transferring the loads through the supports. The appropriate SlackJack and MiniJack device shall be chosen based on the model and series characteristics. The Rated Shrinkage Capacity, Allowable Compression Load, Deflection at Allowable Load and Device Average Travel and Seating Increment, Δ_R , for each model are shown in Table 3.

3.3 The chosen SlackJack or MiniJack device shall be slid over a threaded-rod or anchor bolt, over an approved bearing surface or plate. The appropriate color-coded swivel washer (see Table 4), shall be installed as required by the manufacturer’s installation instructions with the flat side up. A hex nut shall be installed over the rod and hand-tightened.

To place the device into service, the pull clip shall be completely removed and placed on the device to show that the device has been activated.

The product described in this Uniform Evaluation Service (UES) Report has been evaluated as an alternative material, design or method of construction in order to satisfy and comply with the intent of the provision of the code, as noted in this report, and for at least equivalence to that prescribed in the code in quality, strength, effectiveness, fire resistance, durability and safety, as applicable, in accordance with IBC Section 104.11.

Copyright © 2015 by International Association of Plumbing and Mechanical Officials. All rights reserved. Printed in the United States. No part of this publication may be reproduced, stored in an electronic retrieval system, or transmitted, in any form or by any means, electronic, mechanical, photocopying, recording or otherwise, without the prior written permission of the publisher. Ph: 1-877-4IESRPT • Fax: 909.472.4171 • web: www.uniform-es.org • 4755 East Philadelphia Street, Ontario, California 91761-2816 – USA





Where necessary, the devices may be reset in the field. See manufacturer’s installation instructions for details.

4.0 PRODUCT DESCRIPTION

4.1 SlackJack and MiniJack Shrinkage Compensation Devices are spring-loaded, compression-controlled shrinkage compensating devices that are designed to work with threaded-rod or anchor bolt hold-down systems in wood-frame construction. The devices are cylindrical, high-strength structural connectors that enable axial compression travel along a bolted or sliding connection but to withstand movement due to tensile loads.

4.2 The materials used for the inner and outer cylinders, locking rings, springs, pull-clips, capture-rings and swivel washers, for the SlackJack and MiniJack models are shown in Table 1 of this report.

4.3 The model and series number describes the attributes of each shrinkage compensation device. The devices are color-coded to identify the specific model type, which varies based on strength and length of travel. The available travel lengths are: 1 inch, 1 ½ inches, 2 inches, and 3 inches (25.4 mm, 38.1 mm, 50.8 mm, and 76.2 mm). See Table 2 for a description of the model and series notations. Color coding is also used to identify the size of the swivel washer for the SlackJack devices (see Table 4).

5.0 IDENTIFICATION

A label shall be affixed on at least one of the following: product, packaging, installation instructions or descriptive literature. The label shall include the Earthbound name or trademark, the device model number, the IAPMO Uniform ES Mark of Conformity and the Evaluation Report Number (ER-429) to identify the products recognized in this report. A die-stamp label may be used as a substitute for the label. Either Mark of Conformity may be used as shown below:

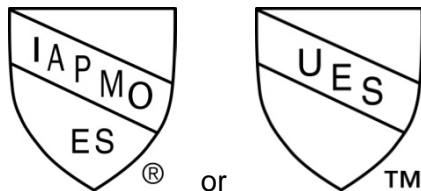

Note: While the present inventory is being depleted, products may alternatively bear markings of “ICC-ES ESR-2848.” Please contact Uniform Evaluation Services if you have any questions.

6.0 SUBSTANTIATING DATA

Data in accordance with ICC-ES Acceptance Criteria for Shrinkage Compensating Devices (AC316).

7.0 CONTACT INFORMATION

Earthbound Corporation

17361 Tye Street S.E.
Monroe, Washington 98272
(800) 944-5669
www.holdown.com

8.0 STATEMENT OF RECOGNITION

This report describes the results of research carried out by the IAPMO Uniform Evaluation Service on Earthbound’s SlackJack and MiniJack Shrinkage Compensation Devices to assess their conformance to the codes and standards listed in Section 1.0 and serves as documentation of the product certification.

Brian Gerber, P.E., S.E.
Vice President, Technical Operations
Uniform Evaluation Service

Richard Beck, PE, CBO, MCP
Vice President, Uniform Evaluation Service

GP Russ Chaney
CEO, The IAPMO Group

For additional information about this evaluation report please visit www.uniform-es.org or email at info@uniform-es.org



TABLE 1 – MATERIAL INFORMATION FOR SlackJack and MiniJack DEVICES

Component	Material
Internal and Outer Cylinders for SlackJack Models S and X	ASTM A513/5 520 DOM Steel
Internal and Outer Cylinders for SlackJack Models T, A and MJ	ASTM B221-08 6061-T6511 Aluminum
Locking Components for all Models	ASTM A313 Stainless Steel
Springs and Pull Clips for all Models	ASTM A764 Galvanized Hard Drawn Spring Wire
Capture Rings for Models T, A and S ¹	Plastic Injection Molded
Capture Rings for Models X, M and S ²	ASTM A513/5 520 DOM Steel or ASTM B221 6061-T6511 aluminum
Swivel Washers	ASTM A108 12L14 Steel

Notes:

1. For S models with a rod diameter of up to 1¹/₈ inches.
2. For S models with a rod diameter greater than 1¹/₈ inches.

TABLE 2 – Model and Series Notations

Notation	
Model Type	MJ = MiniJack A, T, S and X = SlackJack
First Number (Series Type)	2= 2 Locking Rings 3= 3 Locking Rings 4= 4 Locking Rings 6= 6 Locking Rings
Second Number (Rated Shrinkage Capacity)	1 = 1 inch 1-5 = 1.5 inches 2= 2 inches
Third Number (Swivel Washer Code/Color)	See Table 4

Example Nomenclature: SlackJack model with a series number A420, the letter “A” indicates the model number, with the first number “4” which has 4 locking rings. The second number indicates the rated compensation capacity, which in this case is 2 inches and finally, the third number indicates the diameter of the rod and color code for the swivel washer. For example if the rod is ½ inch in diameter, the swivel washer color will be purple.



TABLE 3 - ATTRIBUTES FOR THE SLACKJACK AND MINIACK SHRINKAGE COMPENSATING DEVICES

MODEL ³ & SERIES NUMBER	CAPTURE RING COLOR CODE	SPRING COLOR CODE	NOMINAL DIMENSIONS (inches) See Figure 1 for Dimensions A, B and C			RATED SHRINKAGE CAPACITY (inches)	ALLOWABLE COMPRESSION LOAD ^{1,2} (lbs)	DEFLECTION AT ALLOWABLE LOAD (inch) ⁵	Δ_R^5
			Height Before Activation (A)	Outer Diameter of Body (B)	Inner Diameter of Body (C)				
MJ100 ⁴	Red	Red	2.540	1.349	0.532	1.0	5,000	0.028	0.032
MJ150 ⁴	Green	Green	3.040	1.349	0.532	1.5	5,000	0.030	0.032
MJ200 ⁴	Orange	Orange	3.540	1.349	0.532	2.0	4,900	0.033	0.031
A210	Blue		3.330	2.365	1.420	1.0	7,360	0.013	0.045
A21-50	White		3.830	2.365	1.420	1.5	8,000	0.018	0.047
A220	Yellow		4.330	2.365	1.420	2.0	7,730	0.018	0.050
T410	Orange		3.700	2.365	1.375	1.0	9,000	0.020	0.024
T420	Black		4.700	2.365	1.375	2.0	9,000	0.018	0.028
A410	Red		3.800	2.365	1.250	1.0	14,000	0.022	0.051
A420	Green		4.800	2.365	1.250	2.0	14,000	0.030	0.047
A430	Brown		5.800	2.365	1.250	3.0	1,750	0.033	0.046
T610	Gray		4.325	2.365	1.250	1.0	15,000	0.019	0.035
T620	Purple		5.325	2.365	1.250	2.0	15,000	0.019	0.030
A610	Tan		4.800	2.365	1.250	1.0	20,340	0.028	0.045
A620	White	Blue	5.800	2.365	1.250	2.0	20,100	0.038	0.048
S410	Blue		3.270	2.500	1.625	1.0	22,000	0.020	0.028
S420	Yellow		4.270	2.500	1.625	2.0	22,000	0.026	0.028
X410	Gold		3.700	2.500	1.625	1.0	34,220	0.035	0.047

(Information in Table 3 and Notes 1-4 are from Earthbound QC ("QC") Documentation and Test Data)

Notes to Table 3:

1. "Tabulated allowable loads are for the shrinkage compensating device only. The attached components (including anchors, tension rods, bearing plates, wood framing members, etc.) must be designed to resist design loads in accordance with the applicable code." (QC)
2. "No further increases to the tabulated allowable loads are permitted." (QC)
3. "Model numbers beginning with an A or T are designed for use with W3 through W10 swivel washers capable of fitting over threaded rods or bolts having diameters ranging from 3/8 inch to 1¼ inches. Model numbers beginning with an S or X are designed for use with W10 or W12 swivel washers capable of fitting over threaded rods or bolts having diameters of 1 ¼ inches and 1 ½ inches respectively." (QC)
4. "MJ100, MJ150 and MJ200 Series are for either 3/8 -inch or 1/2 -inch rod diameter. Requires Heavy Hex nut when installing on 3/8-inch-diameter rod." (QC)
5. "The device Δ_R and Δ_A describe the total movement of the device at allowable load, Δ_T , and are additive. For design loads, P_D less than the allowable load, P_A the total movement of the device, Δ_T , is calculated as follows:

$$\Delta_T = \Delta_R + \Delta_A(P_D/P_A) \text{ (AC316)}$$



Table 4 – Swivel Washer Color Code

Number	Diameter of Rod	Color
	0=Base Model	
3	3/8"	Orange
4	1/2"	Purple
5	5/8"	Black
6	3/4"	Gray
7	7/8"	Blue
8	1"	Yellow
9	1 1/8"	White
10	1 1/4"	Green
12	1 1/2"	Red

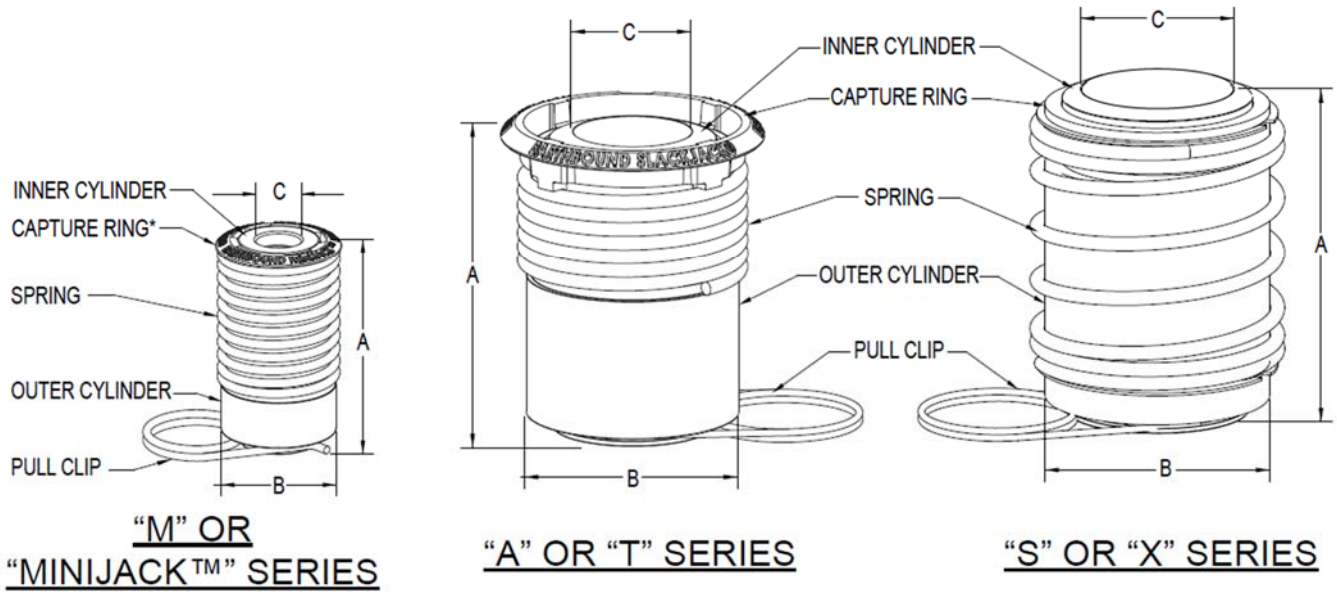

FIGURE 1 - SLACKJACK® SHRINKAGE COMPENSATING DEVICES

*M Series may provide a color coded capture ring in lieu of color coded spring.



CALIFORNIA SUPPLEMENT

EARTHBOUND CORPORATION SlackJack® and MiniJack® Shrinkage Compensation Devices

CSI Section: 06 05 23 - Wood, Plastic and Composite
Fastenings

1.0 RECOGNITION

Earthbound Corporation's SlackJack and MiniJack Shrinkage Compensation Devices evaluated in IAPMO UES ER-429 is a satisfactory alternative to the following codes and regulations:

- 2013 California Building Code (CBC)
- 2013 California Residential Code (CRC)

2.0 LIMITATIONS

Earthbound Corporation's SlackJack and MiniJack Shrinkage Compensation Devices have been reviewed for compliance with the requirements of the CRC and Chapters 16, 16A, 17, 17A and 23 of the CBC and complies when the applicable construction and design requirements of those chapters are used.

For additional information about this evaluation report please visit www.uniform-es.org or email at info@uniform-es.org

Earthbound Corporation
17361 Tye Street S.E.
Monroe, Washington 98272
(800) 944-5669
www.holdown.com



FLORIDA SUPPLEMENT

EARTHBOUND CORPORATION SlackJack® and MiniJack® Shrinkage Compensation Devices

**CSI Section: 06 05 23 - Wood, Plastic and Composite
Fastenings**

1.0 RECOGNITION

Earthbound Corporation's SlackJack and MiniJack Shrinkage Compensation Devices evaluated in IAPMO UES ER-429 is a satisfactory alternative to the following codes and regulations:

- 2014 Florida Building Code, Building (FBC, Building)
- 2014 Florida Building Code, Residential (FBC, Residential)

2.0 LIMITATIONS

Verification shall be provided that a quality assurance agency audits the manufacturers quality assurance program and audits the production quality of products, in accordance with Section (5)(d) of Florida Rule 61G20-3.008. The quality assurance agency shall be approved by the Commission (or the building official when the report holder does not possess an approval by the Commission).

For additional information about this evaluation report please visit www.uniform-es.org or email at info@uniform-es.org

Earthbound Corporation
17361 Tye Street S.E.
Monroe, Washington 98272
(800) 944-5669
www.holdown.com